



DAF XF105



The new standard







The new XF105: comfort, power and performance

Built for the long haul

Low operating costs, best driver satisfaction and high reliability: the key development criteria behind DAF's trucks for the long haul. The XF105 is the best proposition on the market today. It has the most spacious cab in its class, offers top comfort to the driver and high revenues per kilometre to the operator. It's a top performer.

Designed for long distance haulage applications, the cab sets a new standard for driver comfort. With a choice of Space Cab and Super Space Cab – both with generous interior dimensions – the XF105 offers more living, working and storage space than any other truck in its class. The result: drivers stay fit and fresh longer.

Powered for profit

The new 12.9-litre PACCAR MX engine delivers excellent performance: from 410 hp up to 510 hp and high torque of between 2,000 and 2,500 Nm, with a maximum torque available between 1,000 and 1,400 rpm. Also, with DAF SCR Technology it complies with either Euro 4 or Euro 5 exhaust gas emission standards. It is economical too, incorporating several technical advances that reduce fuel consumption. The new XF105 also uses many low-maintenance components, which extends service intervals to further reduce operating costs.

High performance driveline

The driveline is carefully balanced to optimise performance under all operating conditions, and to make the most of the engine's low fuel consumption. There is a choice of either a 16-speed manual or the latest AS-Tronic automated transmission to deliver power to the acclaimed DAF hypoid rear axle. There is also a hub-reduction axle for more demanding applications.

Choice of axle configurations

To ensure that the XF105 is ideally suited to each application it includes a choice of tractors and rigids with two-, three-, or four-axes.



Evolution rather than revolution

A familiar face a new expression

Evolution, rather than revolution, was the starting point for DAF's new flagship truck. The DAF Design Centre gave the XF105 a remarkable and unique appearance, while maintaining the eye-catching character of the hugely successful XF95.

The XF105 has numerous styling and aerodynamic refinements. They include a restyled lower grille, which extends to the bumper and is more pronounced to channel more air and enhance performance. The lower grille also features an aluminium strip to signify compliance with the Euro 4/5 exhaust emission standards, while the upper grille is redesigned with cleaner lines. There is also a newly styled bumper, in which optional cat's-eye combi-lights can now be integrated. The clear headlamps with virtually unbreakable Lexan protection can now also come as Xenon.

Wider field of vision

The four large, electrically adjustable and heated mirrors offer a much larger field of view for increased safety. The stylish aerodynamically designed mirrors are also optionally available in body colour.

Super Space Cab roof

The entirely restyled Super Space Cab roof is both pronounced and stylish. There is a new integrated aerodynamic sun visor. While the optional integrated skylights, with twin 70W halogen spotlights, improve visibility and add an extra touch of style. It all adds up to a unique, powerful presence, both tough and inviting at the same time.

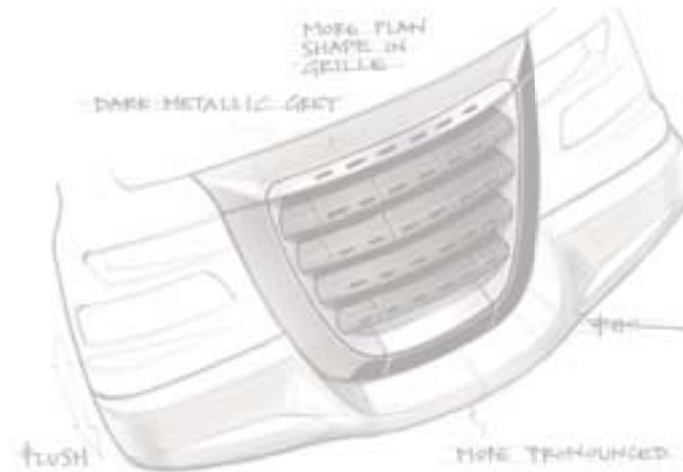

Improved visibility; the restyled mirrors provide a much larger field of view. The optional integrated skylights in the roof of the Super Space Cab and optional cat's-eye combi-lights in the bumper provide extra light.



Comfort with style

New standards in interior design

The XF105 sets totally new standards when it comes to interior design. New standards in the materials and colours which have been chosen, new standards in space and its use, new standards in quality, finish and ergonomics.

The driver was always the most important consideration during the design programme for the XF105. That's true of the attractive door trim to the modern instrument panel, from the logically-positioned handles and switches to the steering wheel that sits comfortably in the driver's hands, right through to the fold-away gear lever. It's true too in the case of the numerous smart storage facilities through to the amber-tone indirect night lighting right across the floor and in the central storage tray.

The best possible standards for the driver.

In every respect, the interior has been designed to provide the best possible standards for the driver. Even the carefully-selected colour combinations give the interior a look and feel that makes working and living in this cab particularly pleasant. Right down to the minutest detail, the wishes and working conditions of the driver have been given top priority.

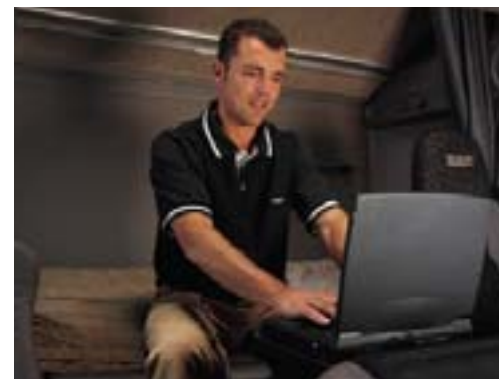

Strong, imposing and impossible to ignore.



DAF

XEBEO

NAVIGATION
A67
300 m
Autobahn

P
N
D
R

25
15
5

Designed to provide the very best working and living space

Safe, comfortable control

Sit in the driver's seat, behind the ergonomically designed steering wheel and it immediately becomes clear that safety, comfort and ease of operation were given high priority during the development of the XF105. This means the driver can fully concentrate on the road, making driving safer and more comfortable.

The newly designed, thick-rimmed four-spoke steering wheel ensures a comfortable grip and clear view of the dashboard instruments. An airbag in the steering wheel is available as an option. Also optional are the illuminated integrated switches that operate cruise control, downhill speed control and the hands-free telephone function. Other key operating functions, including those for the AS-Tronic gearbox, are controlled via easy to operate steering column stalks. Controls on the dashboard as well as the controls for the four large mirrors and window operation on the door console are all back-lit and can be clearly seen at all times.

Information at-a-glance

The main gauges on the modern instrument panel provide information on primary functions, while the central information display presents other essential vehicle information, but only when needed or on the driver's request. This ensures that the driver is not unnecessarily distracted, but

can still receive relevant information. The LCD offers a choice of 10 different languages, and also provides information on trip duration, fuel consumption, average speed and PTO hours.

Computer and phone connections

In addition to the usual dashboard features there are three DIN slots, one above the other. These allow easy installation of not only an audio system but also a navigation system, camera display or on-board computer – it is even possible to integrate multiple functionalities into one unit, the DAF Telematics and Infotainment System. There is also an optional docking station for a mobile phone, which is pre-wired for hands-free connection through controls on the steering wheel. Switches for other functions, including those for the high-capacity heating and ventilation system - with optional automatic temperature control (ATC) - are all located within easy reach.



Adaptable to drivers' needs; the newly designed steering wheel, optionally available in leather, is adjustable both for reach (8 cm) and angle (30° to 45°).

Practical use of space, high quality materials and subtle lighting – unmistakably DAF.



Class-leading interior space

The home away from home

The standing height on the engine tunnel is an impressive 175 cm in the Space Cab and an unprecedented 210 cm in the Super Space Cab - thanks to the lowered engine tunnel, which is just 15 cm high.

Moving from behind the steering wheel to the sleeping area is easy. The gear lever can be folded away and is even entirely absent on the AS-Tronic version, so the passage is unrestricted, and the driver has complete freedom of movement.

Sleeping comfort

The newly designed sleeping area features two spacious bunks. The lower bed is 210 cm long and up to 81 cm wide, and with a 15 cm thick one-piece mattress provides outstanding comfort. It can also be used as a comfortable sofa, from where a dashboard-mounted robust table can be retracted. The upper bunk is easily accessible via a foldaway aluminium ladder with extra wide rungs that feel comfortable even in bare feet. A new easy-lift support system makes it a simple matter to fold away the top bunk. The facility for hanging a towel on the easy lift system illustrates the fact that DAF, like no other manufacturer, understands and meets every driver's detailed wishes.

Ample storage space

Beneath the bunk is space for large storage drawers, with an option for installing a 42-litre refrigerator drawer, in which even large bottles can be stored upright. There is also a standard bottle holder mounted within easy reach of the driver's seat. Many of the other lockers have adjustable partitions and electrical power sockets and are purposely designed flat and square to hold equipment such as a microwave oven, or a TV or coffee machine. It's truly a home away from home.

Refined interior illumination

Relaxing amber-tone indirect night lighting illuminates the floor and central storage tray. And in the Super Space Cab, indirect amber-tone ambient lighting is fitted in the roof console.



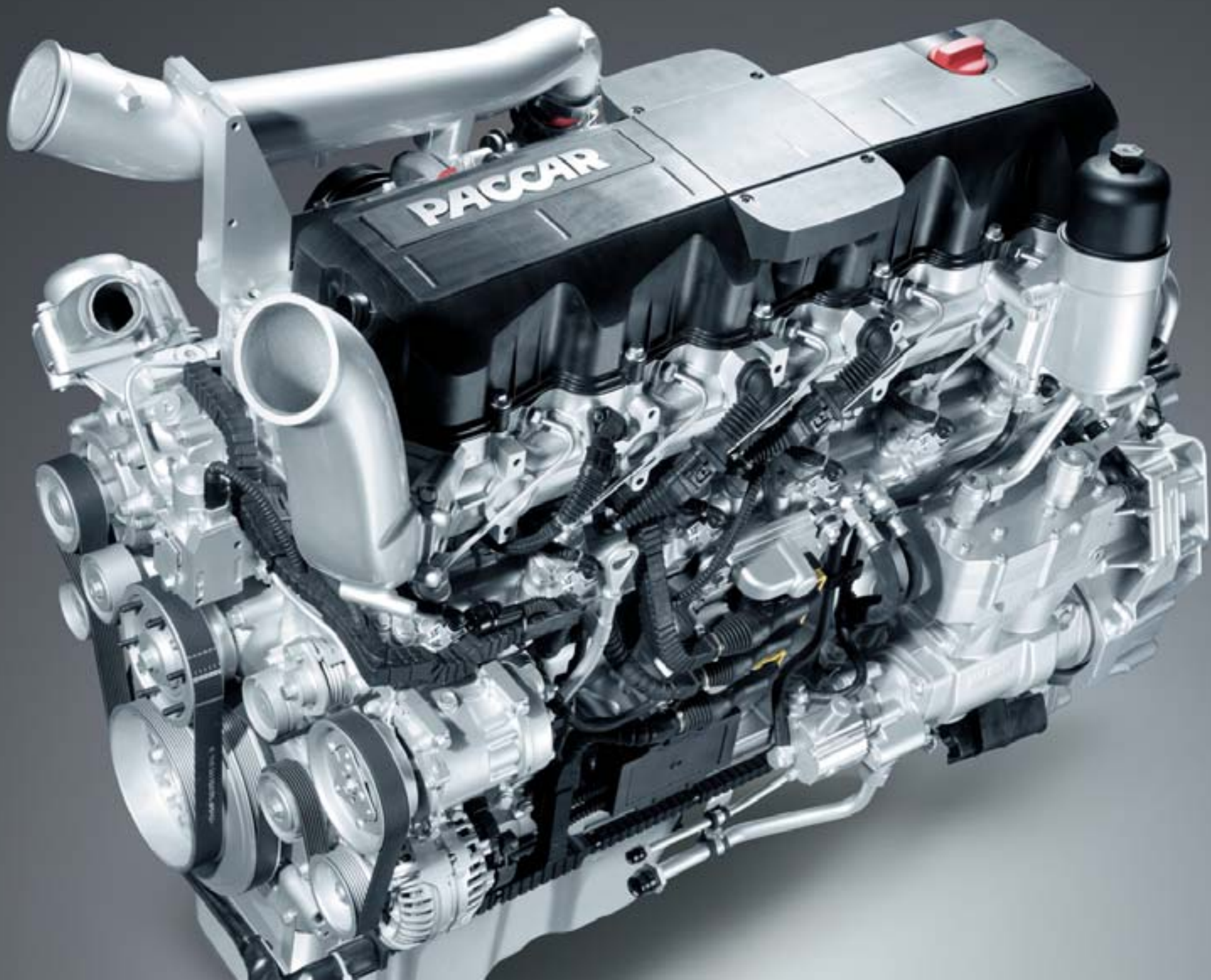

A new range of efficient engines

The power to perform

The all-new PACCAR MX engine, developed and manufactured by DAF, combines excellent high performance with economical fuel consumption. It is available in 410, 460 and 510 hp versions with high torque of 2,000, 2,300 and 2,500 Nm respectively. Importantly, maximum torque is available between 1,000 and 1,400 rpm.

The MX engine can be specified to comply with either Euro 4 or Euro 5 emission standards, thanks to the SMART injection system and DAF SCR Technology, which also makes a separate soot filter redundant. Also, the MX engine can be specified with an excellent integrated engine brake, offering a braking performance from 200 kW at 1,500 rpm to 325 kW at 2,100 rpm.

Longer service intervals

The new engine design results in longer service intervals starting from 90,000 km. Moreover, with a centrifugal filter and the use of synthetic oil, intervals of up to 150,000 km can be achieved, resulting in lower operating costs and maximum vehicle availability. In addition, the use of high-quality materials such as Compact Graphite Iron for the cylinder

block and cylinder head further improve reliability. While extensive function integration results in excellent reliability and durability. The inlet manifold, for example, is integrated in the cylinder head, and the oil filter, oil thermostat and oil cooler are combined in a single oil lubrication module. In fact, there are 25% fewer parts in this new engine, which dramatically increases reliability and prolongs lifetime

Lower operating costs

Integration also results in lower operational costs – maintenance is simpler, faster and therefore less expensive and there are fewer parts that wear and need periodic replacement. Add to that the longer service intervals of up to 150,000 km and the new PACCAR MX engine offers low cost of operation.



Above: the cable harness is coated in rigid foam and is securely fitted so that its weight no longer hangs on the connectors. This eliminates stresses on the connectors and increases reliability. In addition, the ECU does not require separate cooling, which means further parts reduction, more reliability.

Below: the oil filters, the oil thermostat and oil cooler are integrated into one lub-oil module. This is a revolutionary design and industry first, and helps optimise reliability by minimising parts.

Performance, reliability and fuel economy.

The clean route



The integration of the exhaust silencer (with catalytic converter), battery carrier, AdBlue tank, and dosing unit into one compact module leaves enough free space on the chassis for large fuel tanks (up to 1,500 litres) or other equipment.

Depending on the vehicle type, AdBlue tanks are available with a capacity of between 45 to 75 litres: a capacity that corresponds to the diesel fuel tank capacity. This means that the AdBlue tank does not have to be filled more often than the diesel tank. And for added assurance, a special AdBlue level gauge is fitted on the driver's dashboard.

'SMART' injection technology improves combustion efficiency to such a high degree that soot filters are made redundant.

All new DAF trucks feature Selective Catalytic Reduction (SCR) for achieving the stringent Euro 4 or Euro 5 emission requirements. SCR is the best and currently the only economically viable choice for Euro 5. SCR technology is simple, reliable and efficient.

DAF SCR Technology, the clean route to a bright future. As SCR is an after-treatment system, it allows the most efficient combustion in the engine. And DAF goes even further. DAF SCR Technology comes with a whole new range of PACCAR engines with 'smart' injection technology that makes a particulate filter redundant. Optimised combustion leads to class-leading fuel efficiency, performance, durability and reliability. The ideal foundation for low cost of operation and high resale values.

How does it work?

It's simple and effective. Basically the exhaust gas after-treatment system consists of a catalytic converter, a dosing unit and an AdBlue tank with sufficient capacity to match the range offered by the fuel tank. The exhaust gases are led through the catalyst, where AdBlue is injected. A chemical process takes place, resulting in NOx emissions being broken down into harmless water vapour and nitrogen. AdBlue consumption is only 3 to 5% of the diesel consumption, or around 1.5 litres per 100 kilometres.



DAF SCR Technology
for a bright future

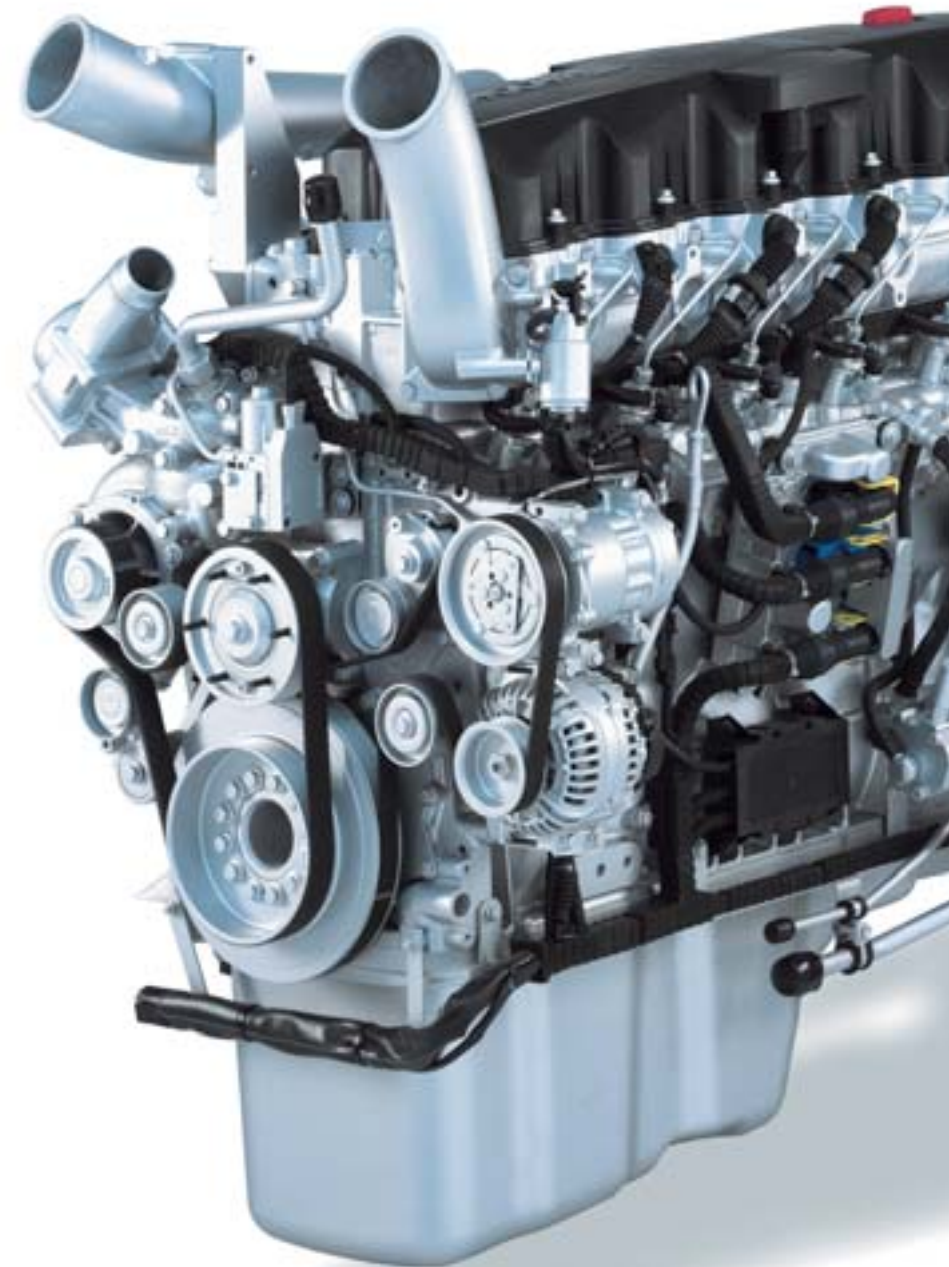

High performance and low fuel consumption

A driveline that's perfect for your unique needs



A fuel-efficient engine alone is not necessarily a guarantee of low fuel consumption; the gearbox and rear axle are also vitally important. That is why DAF pays great attention to integrated driveline technology and offers different drivelines per engine type or transport application, each one optimised so that the total combination of the engine, gearbox and the rear axle will deliver class-leading driveability and excellent fuel efficiency.

The torque of the PACCAR MX engine is significantly higher than that of the previous XEC engine generation. It can therefore reach the same performance with less effort and lower RPM. This makes it possible to create 'faster' drivelines with lower RPM at cruising speed, still maintaining a high performance level.

Wide choice of axle ratios

The XF105 series offers a wide choice of rear axle ratios, including a new 2.69:1 reduction. This extra fast rear axle allows for lower average engine speeds for the best achievable fuel efficiency.

Manual or automated

The DAF XF105 series provides a choice of manual or automated gearboxes. The manual gearbox has 16 speeds and thanks to the 'Servoshift' gear-change device, forces are extremely low and changing gear takes very little effort. For higher comfort and efficiency, the AS-Tronic automated gearshift, with either 12 or 16 speeds, offers state-of-the-art shifting behaviour. This enables the driver to fully concentrate on the road while also increasing the lifetime of the clutch.

Higher productivity by design

A solid foundation

The XF105 comes with a highly compact chassis layout, one that cleverly integrates the exhaust silencer, battery carrier, AdBlue tank, and dosing unit all into one module. Also, by designing the air tanks and brake components layout on the inside of the chassis, space has been created for extra large fuel tanks. The tractor unit can be supplied with a fuel tank capacity of 1,500 litres, which allows refuelling at the home base, or where it best suits the operation.

The robust XF-chassis is made of high quality steel, resulting in an exceptionally strong but lightweight chassis for high payloads.

Two-, three- and four-axle tractors

The XF105 4 x 2 is optionally available with a fifth wheel and offers a wide choice of wheel bases. For transportation of large volumes, DAF can supply a 4 x 2 tractor version that has an extremely low fifth wheel height of only 96 centimetres. This means that trailers with an internal height of nearly three metres can be used for load volumes of up to 100 m³. This so called Low-Deck tractor has a 7.1-tonnes front axle with parabolic springs and an 11.5-tonnes rear axle with a four-bellow air suspension. A front axle with air suspension is also available as an option.

For additional payload capacity, a range of 6 x 2 chassis are available. These come either as double steered and liftable, or as a trailing axle, liftable or steered.

The twin steer 6 x 2 model comes with a steered and liftable rear axle. An important advantage of this leading rear axle is its high yard friendliness. For special, light- or heavy-duty applications, the 6 x 2 tractors are available with liftable trailing axle with single or double mounted tyres.

For operators who need a limited amount of additional payload, DAF can supply the XF105 with a light and non-steered liftable leading axle and with 17.5" wheels.

To complete the tractor range, a 3-axle tractor and a 4-axle tractor with double drive are available – especially suitable for heavy haulage.

Wide range of rigids

The XF105's rigid is completely flat, making it the perfect base for any superstructure. To make the body builder's job as easy as possible, the main frame members are pre-drilled to ensure easy mounting of the body. A Body Builder's Module (BBM) can also be provided to facilitate communication between the electric systems of vehicle and body.

DAF supplies the XF105 rigid as a standard 4 x 2 model with a wide choice of wheel bases. There is also an extended range of 6 x 2 rigids. The trailing-axle versions are available with air suspension on the rear axle, either single- or dual-mounted. Air suspension at the front is optional.

The XF105 is also available as a 6 x 2 rigid with steered trailing rear axle for extra high manoeuvrability and yard-friendliness. The range has been completed with 6 x 4, 8 x 2 and 8 x 4 versions.



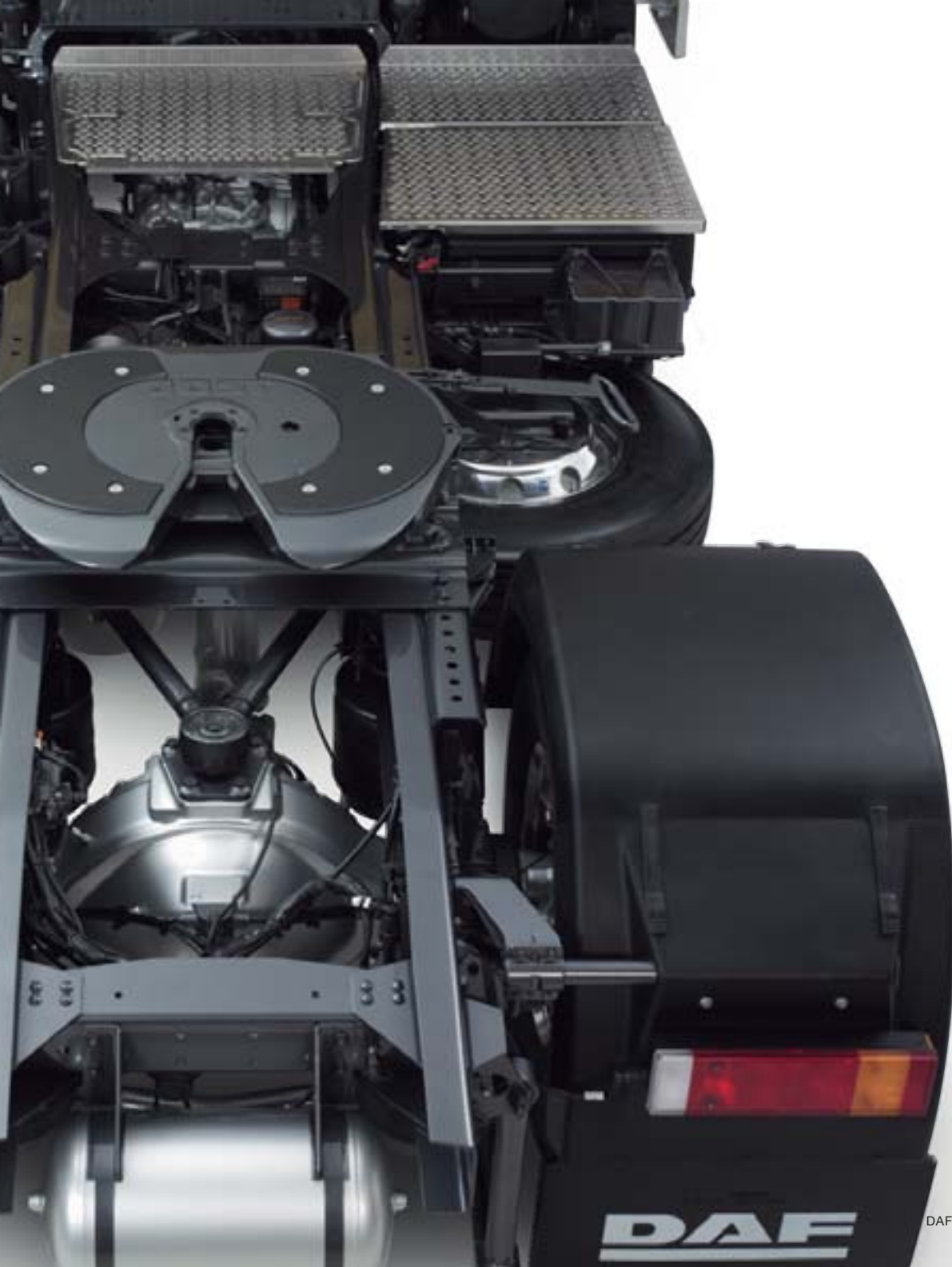

Maximised fuel tank capacity; in the 4 x 2 tractor the air tanks and brake components are inside the chassis, freeing up space for extra large fuel tanks on the tractor: up to 1500 litres.



Quality and reliability for optimum productivity

A joy to drive

All in all, the DAF XF105 is the ultimate driver's truck – a thoroughbred driving machine. With a spacious, comfortable cab, that is well-equipped and beautifully finished in attractive materials and warm colours. It also offers a jewel of an engine delivering up to 510 hp and torque of 2,500 Nm for optimum pulling power and smooth ride.

The accurate steering characteristics mean excellent road holding for safe, comfortable driving. While the electronically controlled braking system, with disc brakes all around and 'Brake Assist'*, optimises braking and safety.

In addition to the easy-to-use controls, the XF105 offers a whole range of optional safety-enhancing features. These include Vehicle Stability Control and airbag with seatbelt pre-tensioners.

Low running cost – high re-sale value

For the operator, the XF105 offers low running costs and high transport efficiency combined with quality and reliability for maximum availability. Long maintenance intervals and professional service from your DAF dealer minimise downtime to further reduce operating costs. The XF105 has also been developed for optimum durability, so that even after travelling many hundreds of thousands of kilometres with its first owner, it still offers a fabulous earning potential for the next. The result is of course a high residual value.

* *Brake Assist is an electronic system that recognises when an emergency brake is being made. It then instantly applies full braking power and therefore increases safety.*







Committed to World Class

Right first time

DAF Trucks - A PACCAR Company - applies state-of-the-art technology to maintain the highest standards in development and manufacturing. Over the last few years, major investments have been made in all DAF-factories. DAF trucks are built in world-class facilities by dedicated people, using high-quality materials and efficient processes.

For the production of the new PACCAR MX engine, the engine factory has been totally renewed, making it one of the most modern of its kind in the world. In other factories too, major innovation programmes have been undertaken to achieve the highest efficiency and quality levels. DAF Trucks introduced World-Class Manufacturing standards: everything right first time, with no unnecessary loss of energy or materials and with the highest conceivable quality. As a result, world-class products are manufactured in world-class factories.

Information Technology

DAF Trucks and its dealers have information technology systems that track a truck and its components throughout its entire life cycle – from design and production to aftermarket customer support. Engineering applies powerful three-dimensional CAD/CAM techniques that seamlessly interface with the production systems; ensuring employees receive detailed on-line work instructions. The vehicle data for each individual

truck is centrally stored for guaranteed traceability, making it easy for dealers to check specifications and order parts – right down to the options fitted.

Product Development

The DAF Technical Centre offers comprehensive research development and testing facilities, including an anechoic chamber for noise measurements and a modern engine laboratory. DAF also has an extensive proving ground for simulating road conditions so vehicle performance can be thoroughly tested. DAF Trucks delivers world-class vehicles designed in world-class development facilities by a world-class development team.

EcoDesign and environmental policy

DAF has had an environmental policy in place for over 10 years, covering all its activities, products, services and locations - including dealers. Its environmental care system is ISO 14001 approved. DAF is committed to conducting its business in a responsible way. EcoDesign is the company's unique approach to environmentally responsible product design, and is concerned with ensuring that all DAF's products comply with the strictest environmental guidelines, from first concept to end-of-life recycling.



DAF uses world class manufacturing standards: right first time; no waste of energy and materials; highest quality standards.

State-of-the-art technology; advanced equipment and IT systems contribute to improved quality and increased efficiency.





A top-class support organization of more than 1,000 independent dealers.



DAF ITS: often copied but never equalled



DAF Telematics and Infotainment System.

DAF's one stop shop offers a total transport solution

With you all the way

Road transport is all about optimum efficiency, so DAF offers a total transport solution, designed to maximize earnings per kilometre. It is supported by a professional organisation and dealer network that helps customers choose the right vehicle, finance it, maintain it in perfect condition, and keep it running at all times.

DAF Trucks not only makes quality vehicles, but also has a first-class back-up organisation with more than 1,000 independent dealers in Europe. They provide support ranging from financial services to repair & maintenance contracts. Parts for truck and trailers are always available, supplied to workshops by PACCAR Parts Distribution Centres in the Netherlands, the United Kingdom and Spain. Every week, over 3,000 shipments are made to dealers and customers across Europe and beyond – often within 24 hours.

Tailored Repair & Maintenance services for improved profitability

By offering a fixed price per kilometre for repair & maintenance, DAF MultiSupport ensures a perfectly maintained fleet without unexpected high costs. Customers can choose the level of services, with options for trailer and body cover. Benefits include increased transparency in operational costs and reduced administration, enabling fleet operators to focus more on the transport business. DAF MultiSupport helps to maximize the return on investment in your vehicle.

Tailor-made financial services

PACCAR Financial has 50 years of experience in the transport industry and understands today's business needs. Services include financing the

total truck combination, R&M contracts and insurance. PACCAR Financial is available at all DAF dealer locations, providing one-stop access for trucks and financial help – including solutions for national and pan-European operators.

Always on stand-by throughout Europe

If something unexpected should ever happen, one telephone call to DAF's International Truck Service (ITS) gets the truck rolling again with minimum delay. Often copied but never equalled, ITS is on stand-by day and night, 365 days a year. Experienced employees mobilize the DAF service organisation, handling language and financial issues to ensure that a stranded truck is back on the road with minimum delay.

Improved business processes with the latest truck-office communication

The DAF Telematics and Infotainment System is designed to optimise business processes at all levels. It provides tracking and tracing, geofencing, navigation, route planning, messaging and camera view. It therefore enables managers to monitor performance and lower costs. Planners will be able to more easily react to changes, and fleet managers can improve maintenance planning. Drivers will drive more efficiently, safe and comfortable.

The DAF Telematics and Infotainment System is based on the highest quality norms and can be easily integrated with current IT systems. Also, because it is prepared for future developments, the investment will pay returns for many years to come.

At DAF, we understand better than anyone else that a truck has to keep moving.

NIEUWE TEKENINGEN VAN VAN GENUGTE VOLGEN!!!

The XF series axle configuration overview

FA	4 x 2	
FAN	6 x 2	
FAR	6 x 2	Single mounted trailing axle
FAS	6 x 2	Double mounted trailing axle
FAT	6 x 4	
FAD	8 x 4	
FAK	8 x 2	
FT	4 x 2	
FTG	6 x 2	
FTP	6 x 2	
FTR	6 x 2	Single mounted trailing axle
FTS	6 x 2	Double mounted trailing axle
FTT	6 x 4	
FTM	8 x 4	

steered axle

driven axle

trailing axle

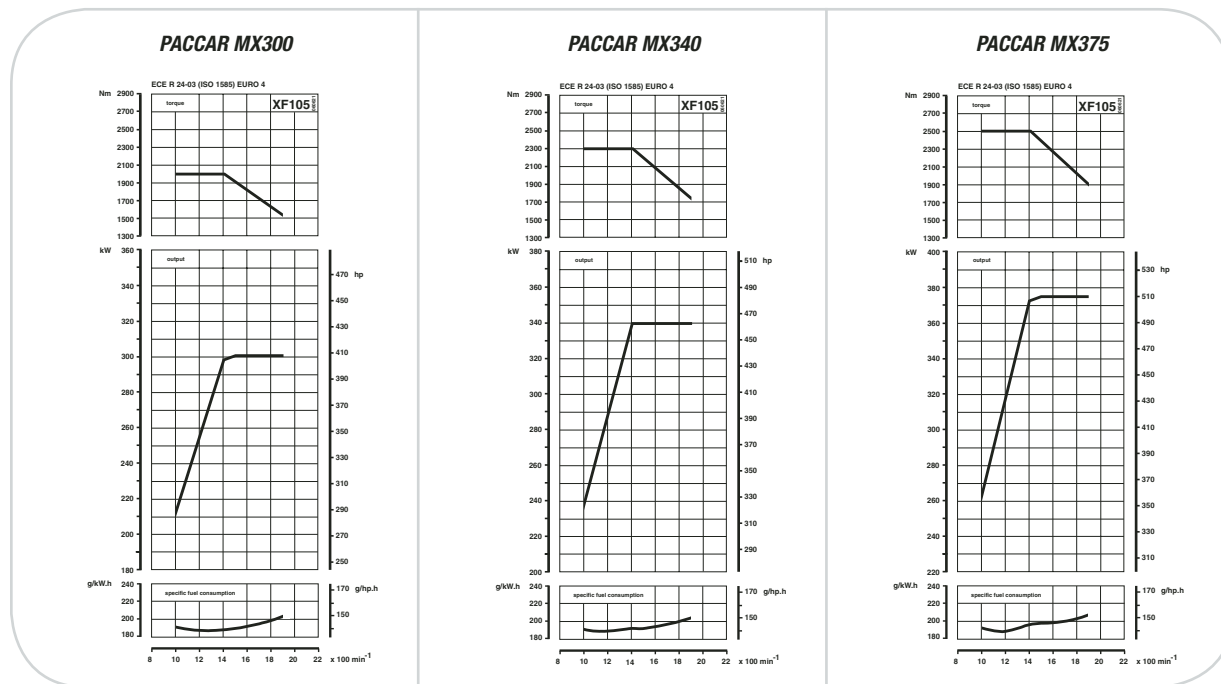

DAF XF105 Super Space Cab

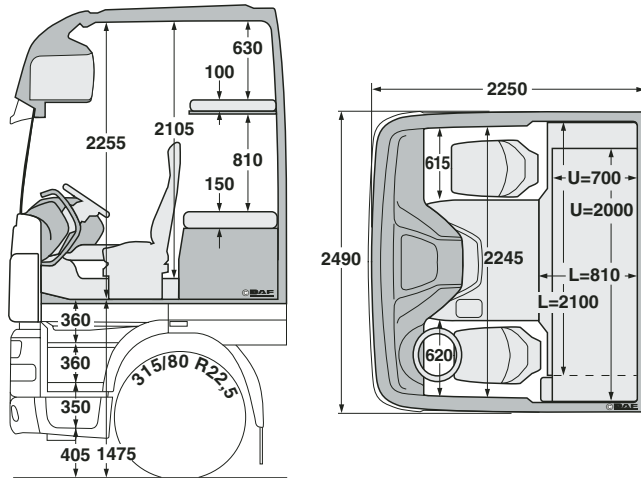

DAF XF105 Space Cab

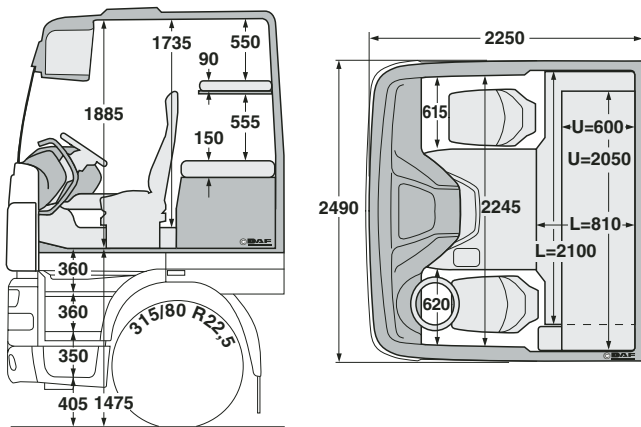

The new XF engine overview

Engine Type	Performance	Torque	Emission level
PACCAR MX engine: 12,9 litre, six-cylinder, turbo intercooler, 4 valves per cylinder			
XF105.410	300 kW / 410 hp from 1500 rpm	2000 Nm at 1000 - 1400 rpm	Euro 4/5
XF105.460	340 kW / 460 hp from 1500 rpm	2300 Nm at 1000 - 1400 rpm	Euro 4/5
XF105.510	375 kW / 510 hp from 1500 rpm	2500 Nm at 1000 - 1400 rpm	Euro 4/5





DAF

DAF XF105



26

The most modern product range on the market

A truck for every need

Every transport application has unique requirements, so every DAF vehicle is unique, built to order from a range of cab, chassis, driveline and axle configurations.

Three vehicle concepts – the XF105, CF and LF – one quality standard: the best. When ordering, the DAF sales specialist guides customer through the selection process using state-of-the-art software, ensuring the specifications exactly match the application.

Whatever the challenge, there's a DAF to meet it.



With a balanced selection of cabs, engines, drive lines and axles, there's a DAF truck that precisely matches your needs, whatever the application.



No rights can be derived from this publication.
DAF Trucks N.V. reserves the right to change
product specifications without prior notice.
Products and services comply with the European
Directives effective at the time of sale but may
vary depending on the country in which you are located.
For the most recent information,
contact your authorized DAF dealer.

DAF Trucks N.V.
Hugo van der Goeslaan 1
P.O. Box 90065
5600 PT Eindhoven
The Netherlands
Tel: +31 (0) 40 21 49 111
Fax: +31 (0) 40 21 44 325
www.daf.com

DW 142030/HQ-GB: 0806

driven by quality



Environmental
Management
System

DAF
A PACCAR COMPANY

